

FEDERAL SUPPLY CLASS
4730

REV.
E

AS33514™

RATIONALE

TYPO CORRECTED TO SURFACE FINISH IN FIGURE 2, DETAIL AA FOR THE 24° SLOPE.

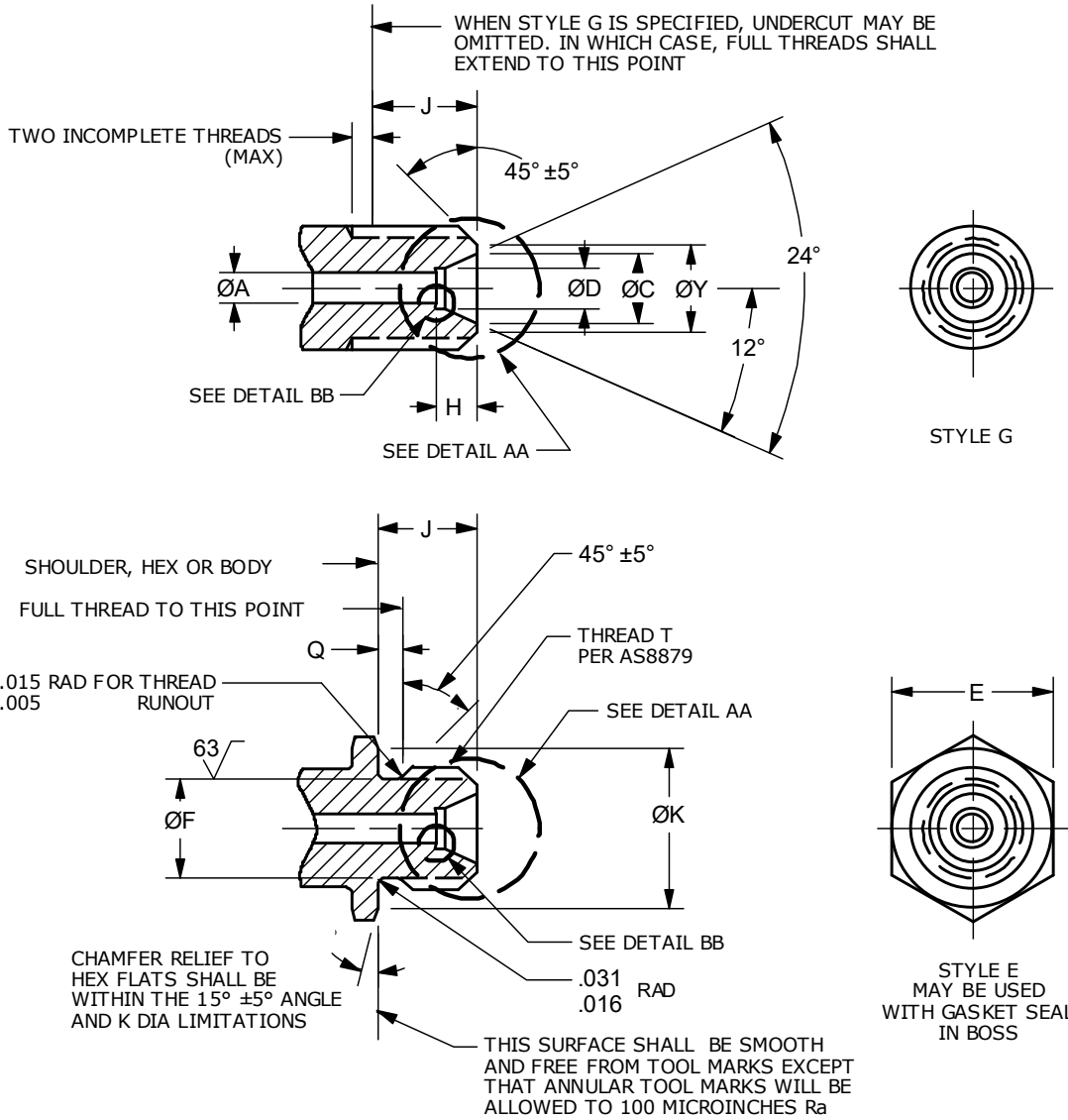
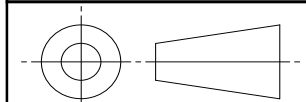

FIGURE 1 - STYLE E AND G

INACTIVE FOR NEW DESIGN /4/

SAE values your input. To provide feedback on this Technical Report, please visit <http://standards.sae.org/AS33514E>

THIRD ANGLE PROJECTION



CUSTODIAN: G-3/G-3B

PROCUREMENT SPECIFICATION: NONE



AEROSPACE STANDARD

FITTING END, STANDARD DIMENSIONS FOR FLARELESS TUBE CONNECTION AND GASKET SEAL

AS33514™
SHEET 1 OF 3

REV.
E

SAE Technical Standards Board Rules provide that: "This report is published by SAE to advance the state of technical and engineering sciences. The use of this report is entirely voluntary, and its applicability and suitability for any particular use, including any patent infringement arising therefrom, is the sole responsibility of the user." SAE reviews each technical report at least every five years at which time it may be revised, reaffirmed, stabilized, or cancelled. SAE invites your written comments and suggestions.

ISSUED 1998-08 REAFFIRMED 2015-04 REVISED 2019-04